

Date:	Project Name:
Type:	Part Number:





# HELIOS SERIES

## LED WRAP AROUND

### FEATURES

- DLC Premium
- Dual Voltage 120-347V
- 0-10V Continuous Dimming
- Surface or Suspension Mounting options
- Easy and Safe Installation
- Frosted Polycarbonate Lens
- Rated Lifetime L70(hrs) : >100,000
- Ambient Temperature: -22°F to 122°F (-30°C to 50°C)
- Suitable for Damp Locations
- Includes Coverplate and V-Hangers
- Sensor Available
- CRI > 80
- 5 year warranty

### APPLICATIONS

-  Corridors
-  Education Facilities
-  Low Bay Application
-  Multi-res/Retirement



**\*THE MAXIMUM HEIGHT THIS FIXTURE CAN BE MOUNTED FOR OPTIMAL SENSOR FUNCTION IS 12-13FT. IF MOUNTED ABOVE THIS HEIGHT MOTION WILL NOT BE DETECTED AS PRECISELY\***

Date:	Project Name:
Type:	Part Number:

## SPECIFICATION

ORDER#	MODEL#	WATTS	VOLTAGE (V)	HOURS RATING	EFFICACY lm/W	CCT (K)	DLC PREMIUM
R38003	RENO-HWR2-MW-DV-MCCT-MS	12/15/18/22W	R38001	100,000	130 lm/W	35/40/50K	✓
R38004	RENO-HWR4-MW-DV-MCCT-MS	22/28/34/44W	R38001	100,000	130 lm/W	35/40/50K	✓

## ACCESSORIES

ORDER#	MODEL#	DESCRIPTION
R83004	RENO-EM-C08	EMERGENCY LED DRIVER

## SENSOR OPTIONS

ORDER#	MODEL#	DESCRIPTION
R74002	RENO-SENSOR-PIR-H-EX	For external mounting when installed above 13FT

## REMOTE OPTIONS

ORDER#	MODEL#	DESCRIPTION
R73002	RENO-REMOTE-H	Remote Control

Date:	Project Name:
Type:	Part Number:

## DIMENSIONS

**2FT.**

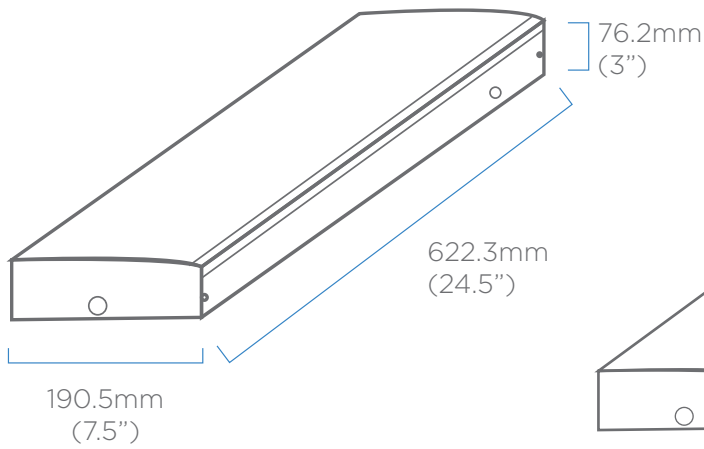

**4FT.**

